

Charisma™ LED Single Sided Light Box - XBX Series

Page 1 - Assemble the Frame

First start by assembling corners. There are three (3) brackets per corner. All extrusion sections are numbered to identify which pieces go together, 1 with 1, 2 with 2, etc.

1. Insert the flat L brackets with the two (2) set screws into the back of one extrusion segment as shown. Identical bracket with no holes goes between bracket and the extrusion, as shown in the images below. Lightly screw into place, DO NOT fully tighten.
2. For Bent Corner Bracket: Insert the bent bracket into the same extrusion section. Firmly screw the bracket into place. Take the mating extrusion piece with matching number. Guide the corner brackets in, then tighten all brackets.
3. Repeat assembly steps for the three remaining corners
4. For larger boxes, sides may be built in multiple sections. These sections end in a straight cut (NOT a 45° angle). Use the three (3) straight brackets to connect the two adjoining sections. The screws will be tightened from the inside of the frame. Sections can be identified with matching numbers.
5. If provided, place center support bar bracket into frame channel and use the Allen key to expand the bracket inside the channel to secure it in place.

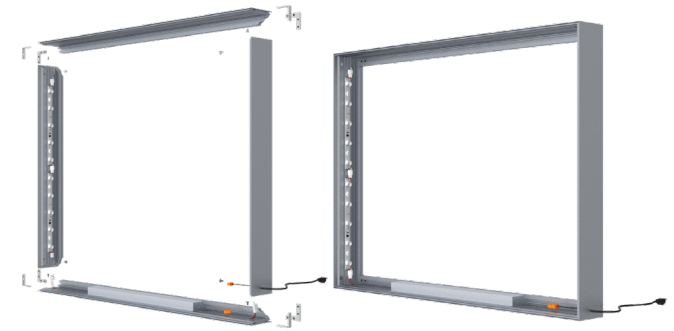

XBX34 shown

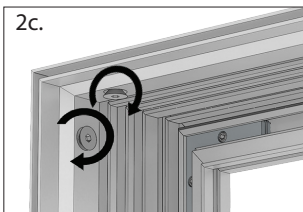
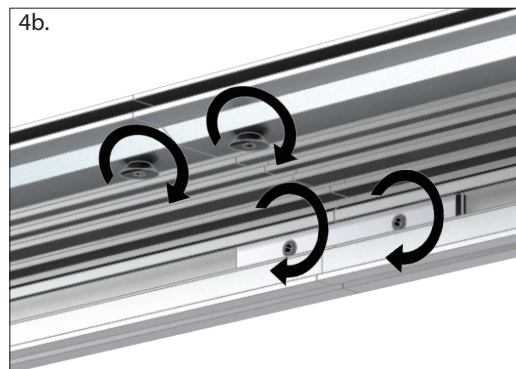
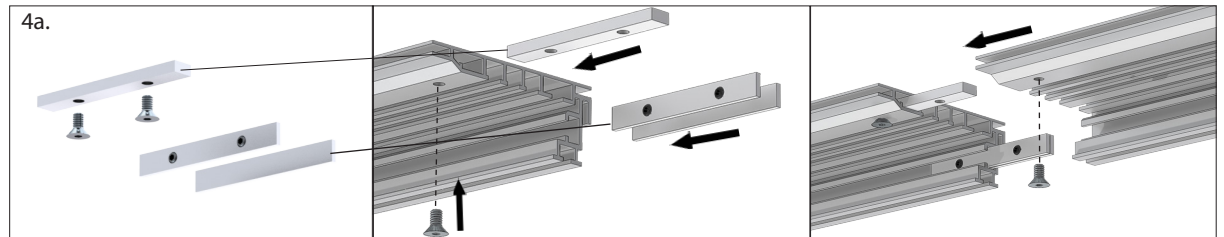
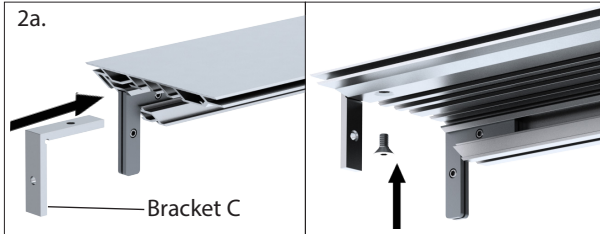
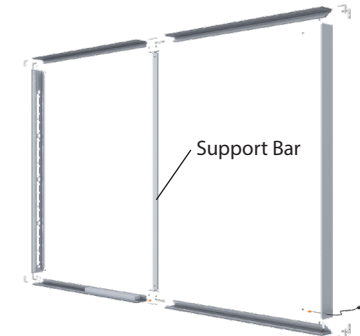
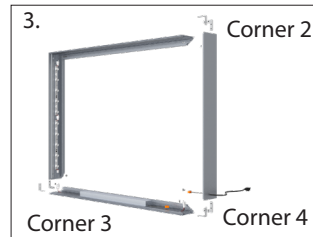
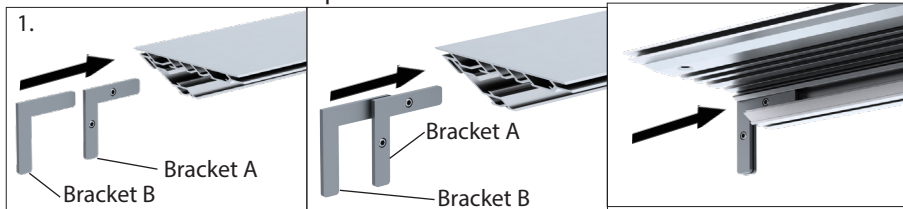

Charisma™ LED Single Sided Light Box - XBX Series

Page 2 - Connect Electrical Components

1. At each break in the extrusion, identify the orange or white electrical connector. Then connect the white female connectors to their matching male connectors and the orange female connector to their matching male connector. The connectors must fully "click" together.
2. It is normal for the last female white connector to be unconnected to anything else.
3. If there are multiple cables, connect those with matching colors (not shown).

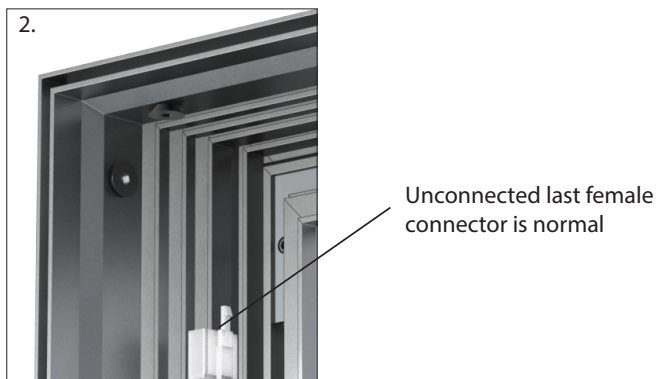
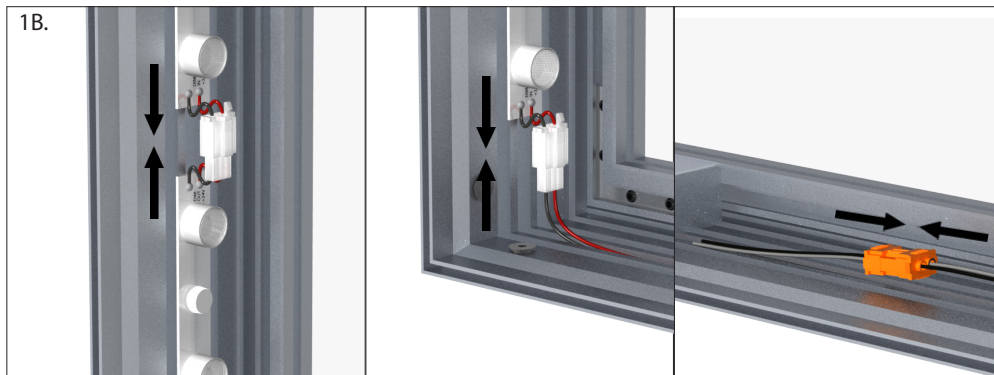

ELECTRICAL NOTE:

This sign is intended to be installed in accordance with the requirements of Article 600 of the National Electrical Code and/or other applicable codes. This includes proper grounding and bonding of the sign.

Charisma™ LED Single Sided Light Box - XBX Series

Page 3 - Install Fabric Backer

Most frames will use a fabric backer (optional) to reflect light forward to the graphic.

1. Identify the back of the extrusion as shown below.
2. To install the fabric backer in the back of the extrusion, take the corner A with the pull tag on it and press about 6"-10" of silicone into the frame channel. Repeat for the opposite corner B. Repeat for the next corner C. Lastly, repeat for the final corner D.
3. After all corners are pressed in, press the silicone into the frame channel at the mid-points on all four sides.
4. Press silicone into frame evenly between the corner and midpoints.
5. To remove the fabric backer from the frame, simply pull up on the pull tag.

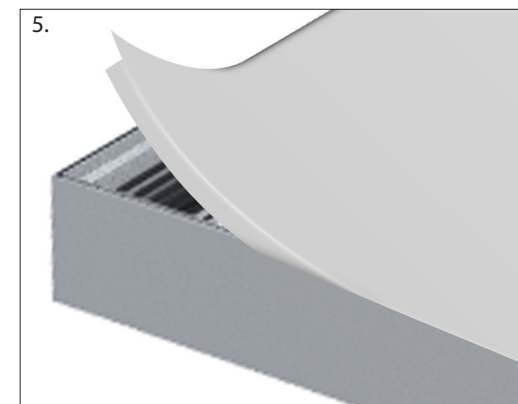
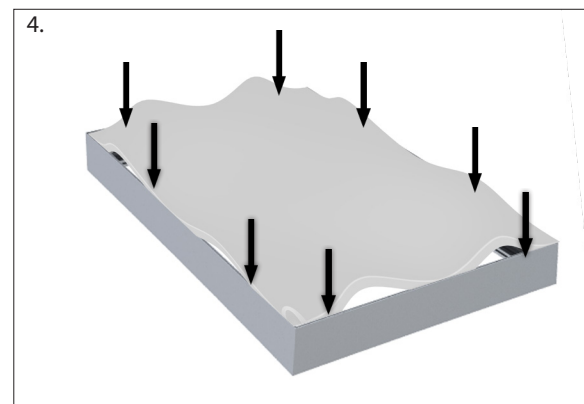
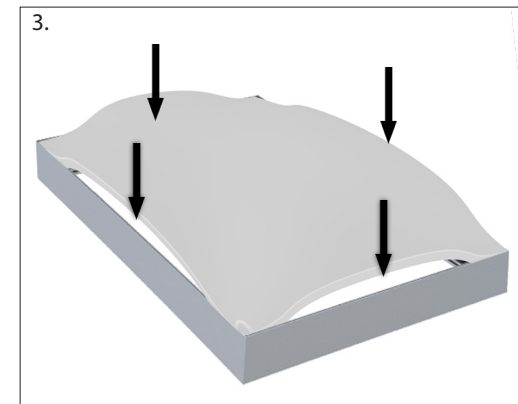
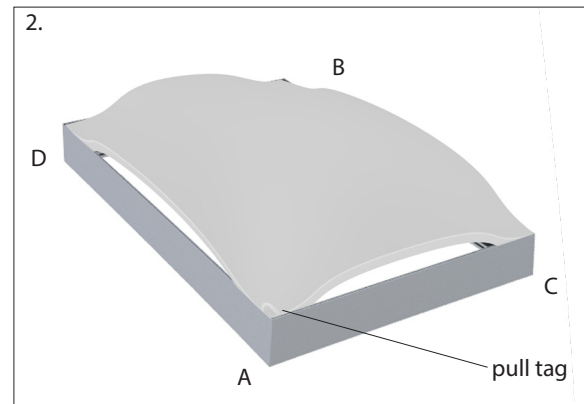
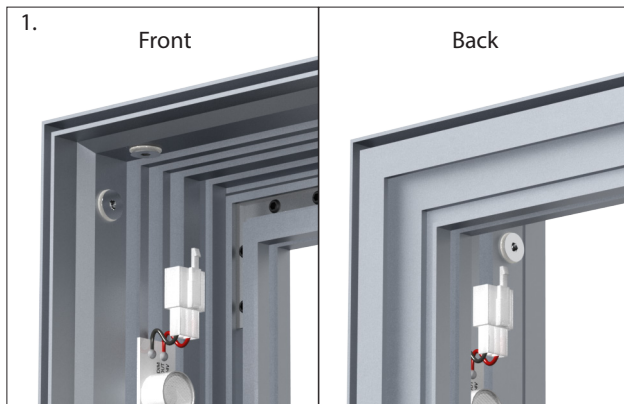

Charisma™ LED Single Sided Light Box - XBX Series

Page 4 - Mounting

Page 4 - Mounting

1. WALL MOUNT: *Drill mounting holes in the frame as needed, to align with the EXISTING WALL STUDS.* Using an X-acto blade or hole puncher, puncture or cut small holes into the white backing graphic to match the holes just drilled in the frame, then mount to the wall (Mounting screws and anchors not provided - ensure the appropriate type for your wall).
2. HANG: the frame using the pre-mounted eyebolts, after installing graphic (see next page for graphic installation).
3. BASES: Mount the frame to the bases using the nuts, washers, and screws provided.

CAUTION: Always ensure the frame is secured strongly without risk of falling before completing the installation.

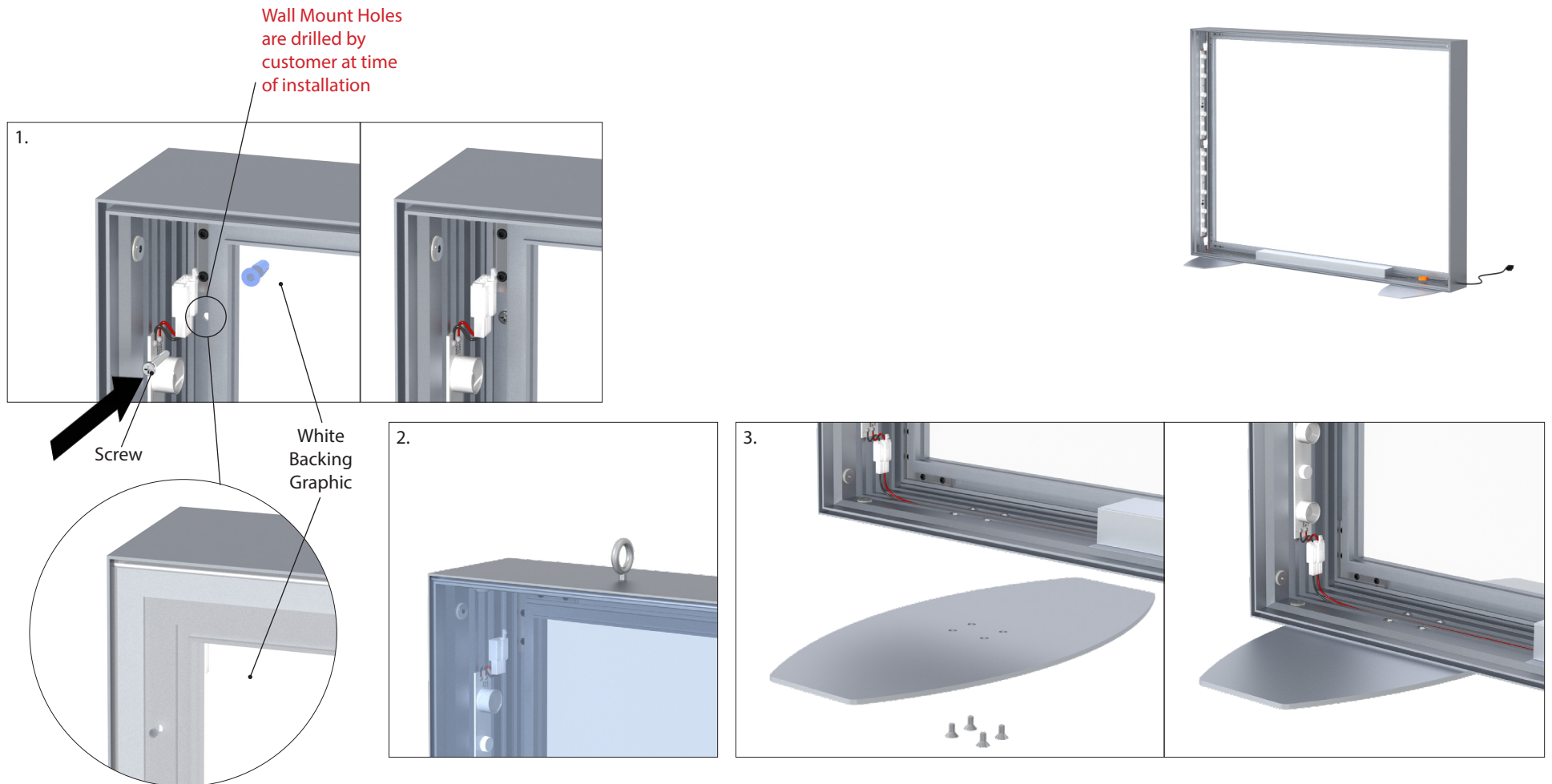
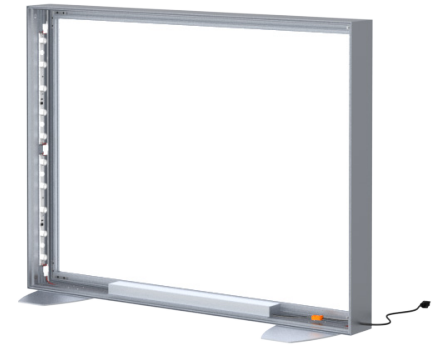
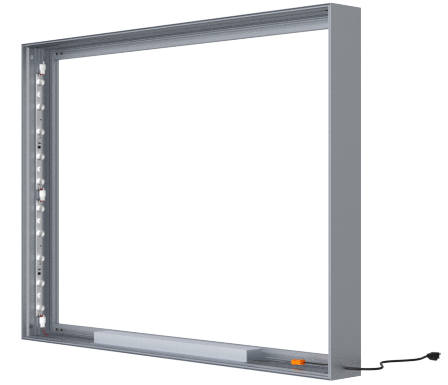

Charisma™ LED Single Sided Light Box - XBX Series

Page 5 - Install the Graphic

1. Plug frame into wall outlet.
2. To install the graphic, take the corner with the pull tag on it and press about 6"-10" of silicone into the frame channel corner A. Repeat for the opposite corner B. Repeat for the next corner C. Lastly, repeat for the final corner D.
3. After all corners are pressed in, press the silicone into the frame channel at the mid-points on all four sides.
4. Press silicone into frame evenly between the corner and midpoints.
This prevents the graphic from bunching up or stretching too much and will ensure a smooth and tight fit.
5. To remove the graphic from the frame, simply pull up on the pull tag.

NOTE: Model shown below may differ from your model, but assembly instructions remain the same.

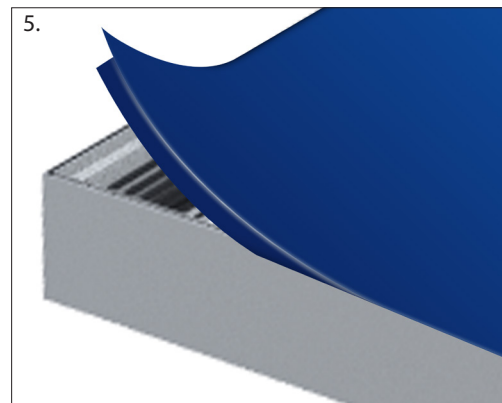
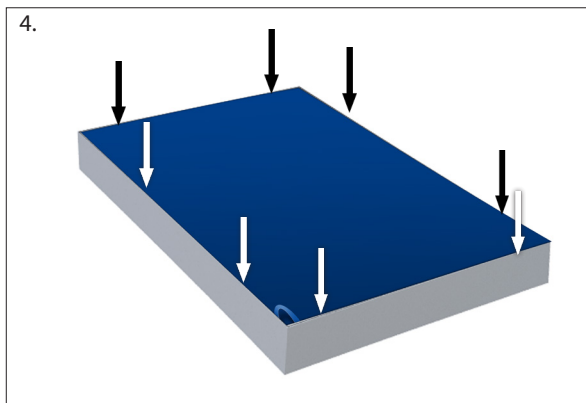
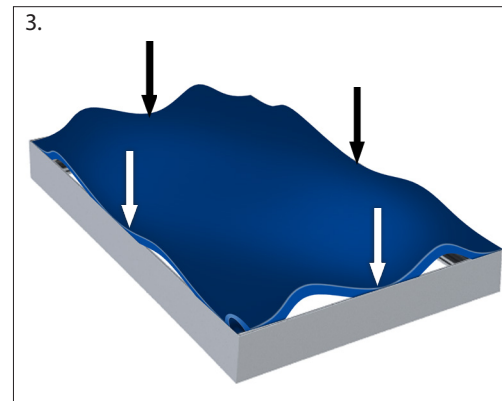
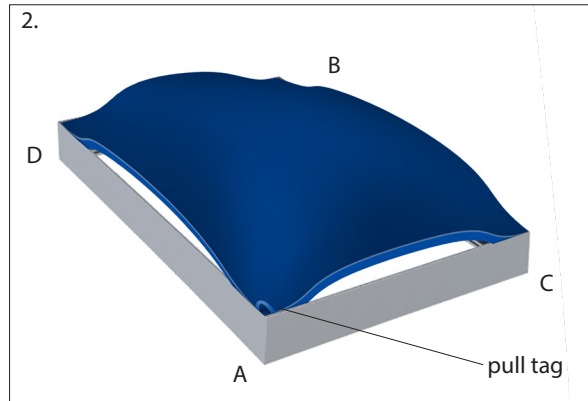
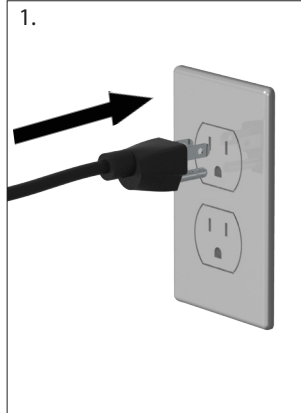
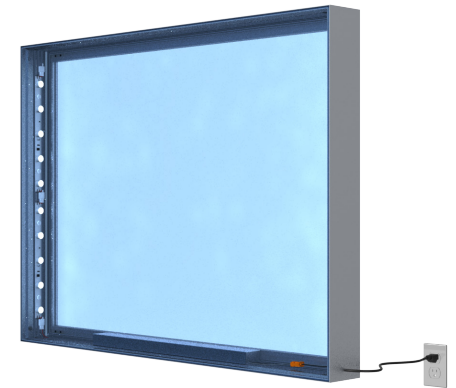

Charisma™ LED Single Sided Light Box - XBX Series

Page 6 - Repair Instructions - Light Replacement:

1. Unplug unit from wall.
2. Remove thumb screws from light strip.
3. Unplug the light strip male/female connectors, then remove the light strip.
4. Refasten the new light strip with the thumb screws, but do not tighten completely.
5. Reconnect the new light strip to the adjacent connections.
6. Tighten the thumb screws to secure the position.
7. Plug in the unit.

ELECTRICAL NOTE:

This sign is intended to be installed in accordance with the requirements of Article 600 of the National Electrical Code and/or other applicable codes. This includes proper grounding and bonding of the sign.

